

MD620

Double Balanced Mixer 3...20 GHz



- frequency range 3...20 GHz
- frequency range IF 0.001...5 GHz
- conversion loss <14 dB
- Isolation LO – RF 35 dB
- LO input power +15 dBm
- RF max power input $P_{IN} = +27$ dBm

Application

- telecommunications
- radars
- test and measurement equipment

The MD620 is a passive double balanced mixer based on GaAs Schottky diode technology. It is ideally suited for applications where small size is needed. RF and LO frequencies range from 3 to 20 GHz, IF frequency range goes from 0.001 to 5 GHz. This mixer can operate at a +15 dBm LO drive level with a conversion loss less than 12 dB. The MD620 is compatible with conventional die attach methods, which makes it ideal for MCM and hybrid-integrated microwave modules with general sealing.

Electrical specification (T = 25 °C)

Symbol	Parameter	Min.	Type	Max.	Min.	Type	Max.	Unit
$\Delta F_{LO}, \Delta F_{RF}$	Frequency range LO and RF	3...10			10...20			GHz
ΔF_{IF}	Frequency range IF	0.001...5						GHz
CL	Conversion loss	—	7	12	—	8	10	dB
ISO_{LO-RF}	LO to RF Isolation	30	35	—	35	37	—	dB
ISO_{LO-IF}	LO to IF Isolation	22	25	—	18	22	—	dB
ISO_{RF-IF}	RF to IF Isolation	30	32	—	22	25	—	dB
IIP3	Input IP3	11	16	—	16	20	—	dBm
IIP2	Input IP2	15	17	—	12	15	—	dBm
P1	1 dB Gain compression (input)	8	10	—	10	11	—	dBm
P_{MAX}	RF max power input	+27						dBm

NOTE All measurements are performed with LO input power $P_{LO} = +15$ dBm

Schematic circuit

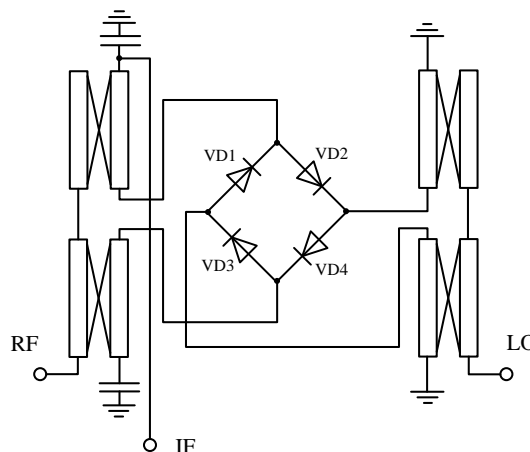

Specifications are subject to change without notice.

Functional block diagram

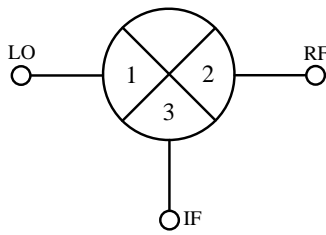

Configuration A

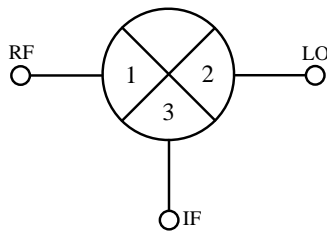

Configuration B

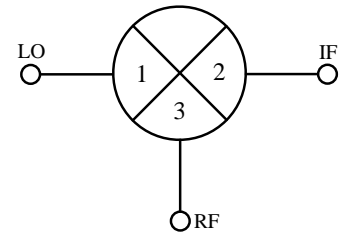

Configuration C

NOTE Depending on the power-on configuration of the MD620, it is possible to obtain the optimum parameters for a particular component application.

Typical characteristics (T = 25 °C)

Conversion Loss (config. A), $F_{IF} = 90$ MHz

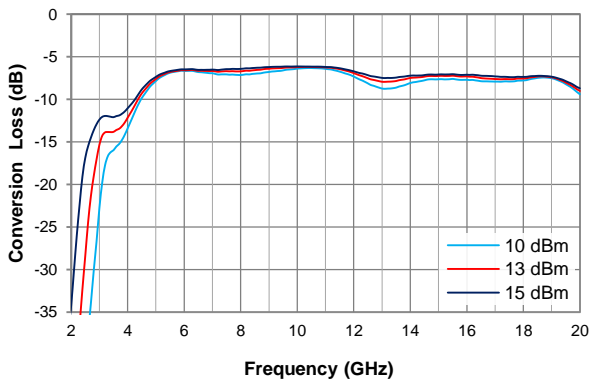

Conversion Loss (config. B), $F_{IF} = 90$ MHz

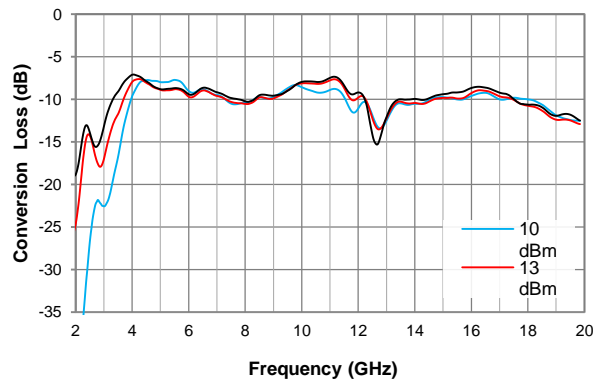

Conversion Loss (config. C), $F_{RF} = 5$ GHz

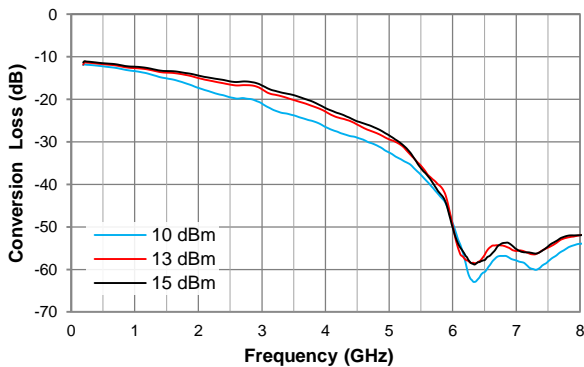

Conversion Loss ($2F_{LO}$), $F_{IF} = 99$ MHz

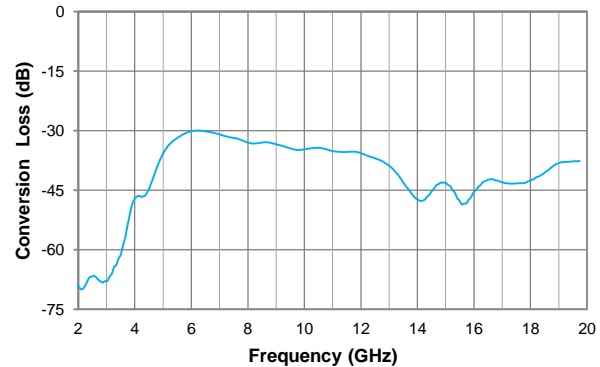

Conversion Loss (3F_{LO}), F_{IF} = 99 MHz

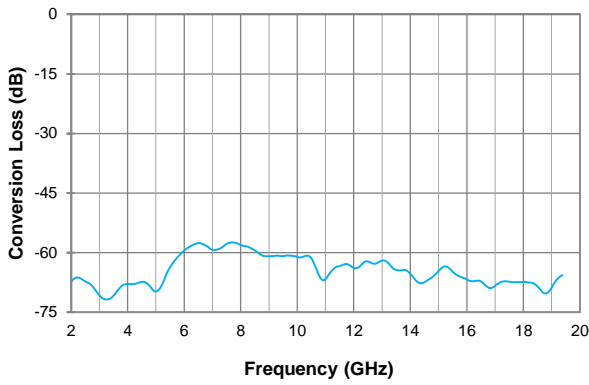

Input P_{1dB}, F_{IF} = 50 MHz

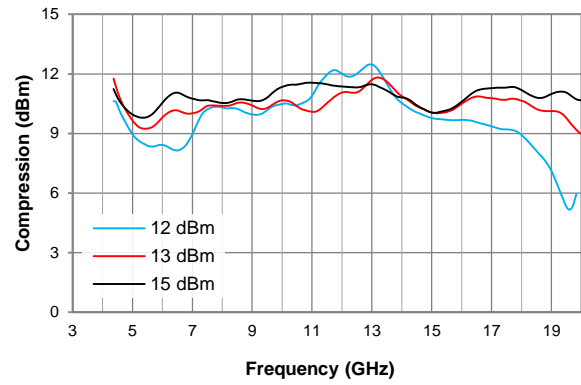

Isolation, P_{LO} = 15 dBm

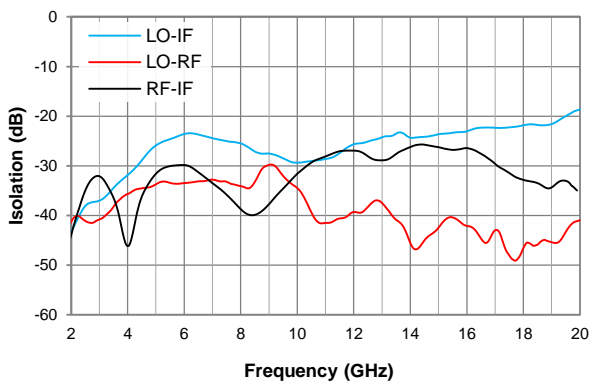

Return Loss

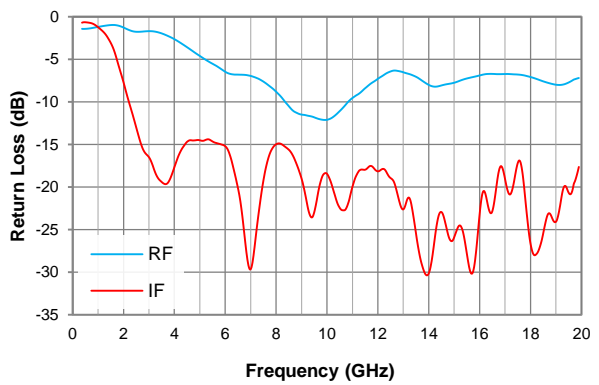

Input IP₂, F_{IF1} = 34 MHz, F_{IF2} = 35 MHz

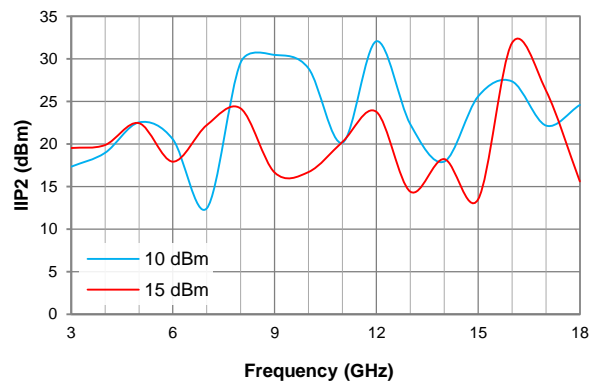

Input IP₃, F_{IF1} = 34 MHz, F_{IF2} = 35 MHz

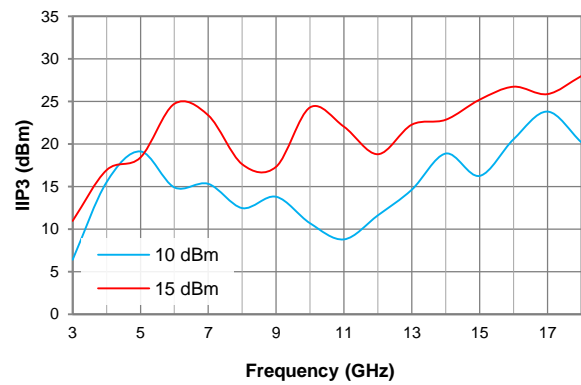

Mechanical data

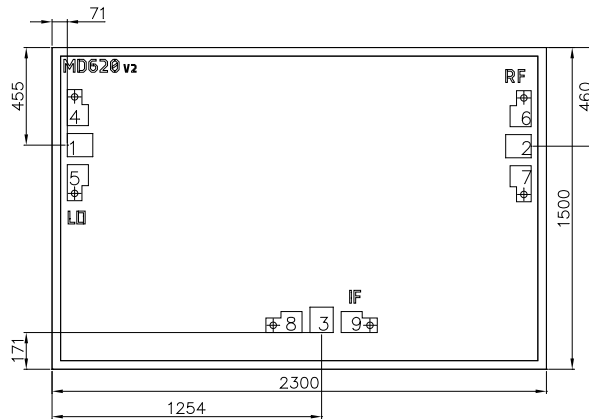

- Chip size is 2 300 × 1 500 μm (before wafer dicing), thickness 100 μm.
- Position coordinates are shown for the bond pad center.
- Bond pad and backside are metallized with gold.
- Pads are 100 × 100 μm.

Pad number	Pad ID	Description
1	LO	LO input
2	RF	RF input / output
3	IF	IF input / output
4	—	GND
5	—	GND
6	—	GND
7	—	GND
8	—	GND
9	—	GND

Assembly diagram

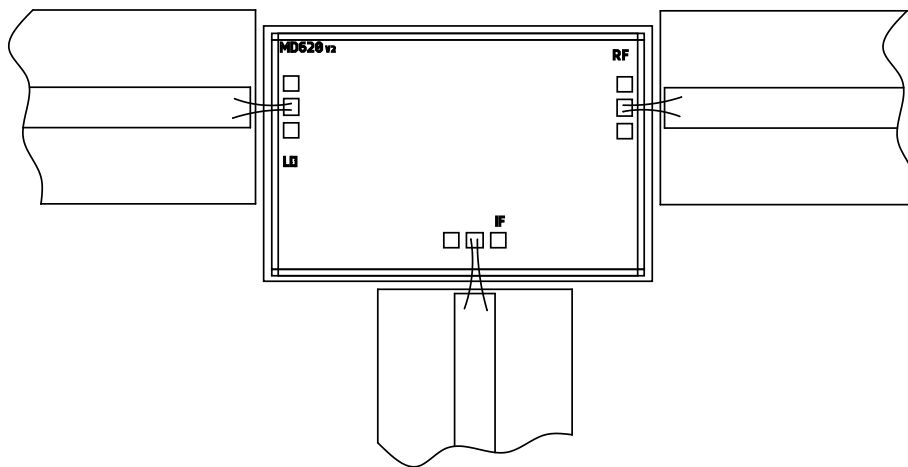

Specifications are subject to change without notice.

Application notes

Mounting

The chip is back-metallized with gold and can be die mounted with AuSn eutectic alloy or with electrically conductive adhesive. The mounting surface should be clean and flat. The 50 Ohm Microstrip transmission, mounted on 0.127mm thick alumina and thin film substrates, is recommended for bringing RF to and from the chip (Figure 1). One way to accomplish this is to attach the 0.102 mm thick die to a 0.150 mm thick molybdenum heat spreader (molytab) which is then attached to the ground plane (Figure 2). Microstrip substrates should be located as close to the die as possible in order to minimize bond wire length. Typical die-to-substrate spacing is 0.1mm.

Wire Bonding

It is recommended for RF pads to use a wire 25 µm in diameter and 300 µm in length.

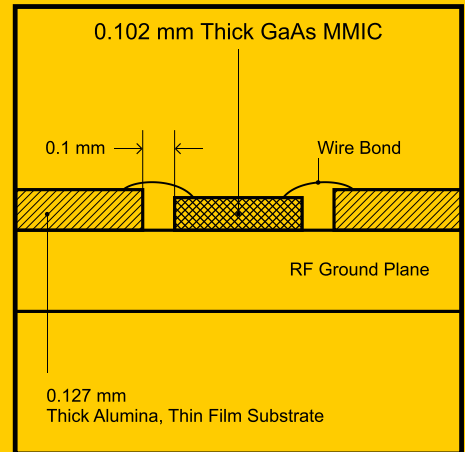

Figure 1.

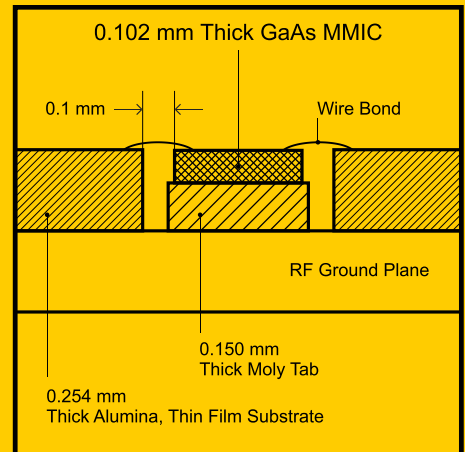

Figure 2.

Recommended ESD Management

This device is susceptible to electrostatic and mechanical damage. Dies are supplied in antistatic containers, which should be opened in cleanroom conditions at an appropriately grounded antistatic workstation. Devices need careful handling using correctly designed collets, vacuum pickups or, with care, sharp tweezers.

