

MD215D

SPDT Non-Reflective Switch



- frequency range 0.01...20 GHz
- insertion loss 1.7 dB at 10 GHz, 2.4 dB at 20 GHz
- high isolation > 40 dB

Application

- test and measurement equipment
- telecommunications
- radars

The MP215D is a high-performance MMIC SPDT Non-Reflective Switch, which covers the frequency range from DC to 20 GHz and can be used in telecommunications, test and measurement equipment and radar applications. This chip based on 0.5 μm GaAs pHEMT technology. The MP215D is ideal for hybrid-integrated microwave modules with general sealing. The MMIC uses gold bond pads and backside metallization and is fully protected with Silicon Nitride passivation to obtain the highest level of reliability. The switch is managed by digital power control driver in TTL standard.

Electrical specifications (T = 25 °C)

Symbol	Parameter	Min.	Typ.	Max.	Unit
ΔF	Frequency range	0.01	—	20	GHz
IL_{ON}	Insertion loss DC to 10 GHz	—	1.7	1.8	dB
IL_{ON}	Insertion loss DC to 20 GHz	—	2.4	2,5	dB
IL_{OFF}	Isolation	40	—	—	dB
RL	Return Loss	12	—	—	dB
P1dB	Input Power at 1 dB Compression Point	20	—	—	dBm
t_{RISE}, t_{FALL}	Switching speed	—	—	60	ns
VSS	Supply voltage for driver	—	-5	—	V
VLH	Control voltage high	+2.2	+3.3	+5	V
VLL	Control voltage low	0	—	+0.7	V
I_VSS	Supply voltage for digital control driver	—	—	2.5	mA

Absolute maximum ratings

Parameter	Value	Unit
Supply Voltage for Digital Control	-7.5	V
Control Voltage	0...+5.5	V
Bias current	40	mA
Operating Temperature	-60...+85	°C
Storage Temperature	-60...+125	°C

Application circuit

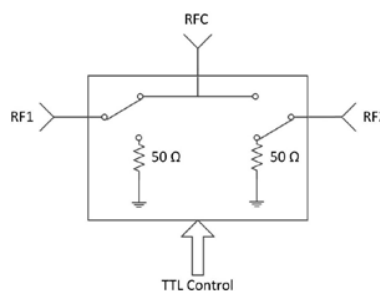

Specifications are subject to change without notice.

Switch Control Bias

Control driver is integrated in the device to supply the necessary internal switching voltages for the switch cells. The reference state is enabled with low voltage (0V) on the control pad of the switch (6). The binary weighted switch states are switched by applying high voltage on the respective control pad. A control table for the switch is presented below.

State table

MMIC state	Control voltage (A1), V
Path 1	0...0.8
Path 2	2.2...5.0

Typical characteristics (T = 25 °C)

Insertion Loss

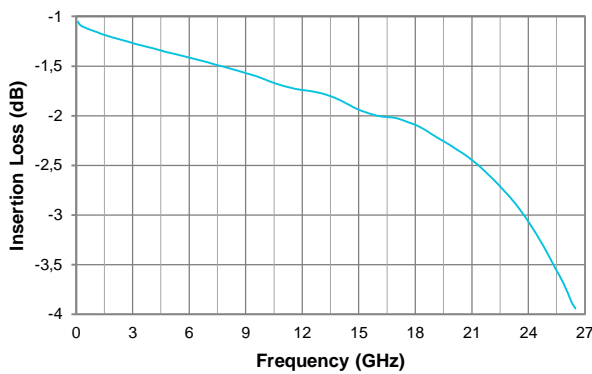

Isolation

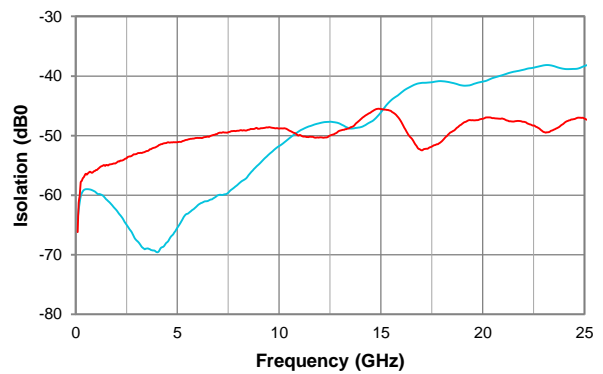

Return Loss

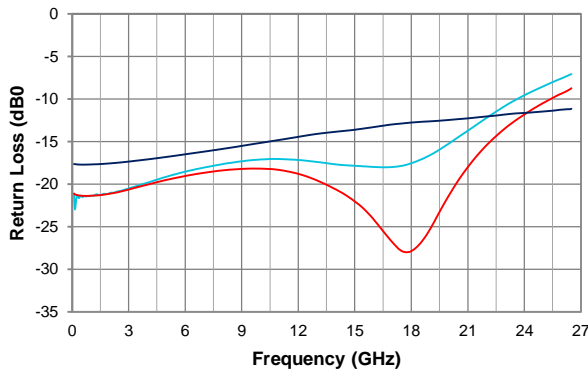

Mechanical data

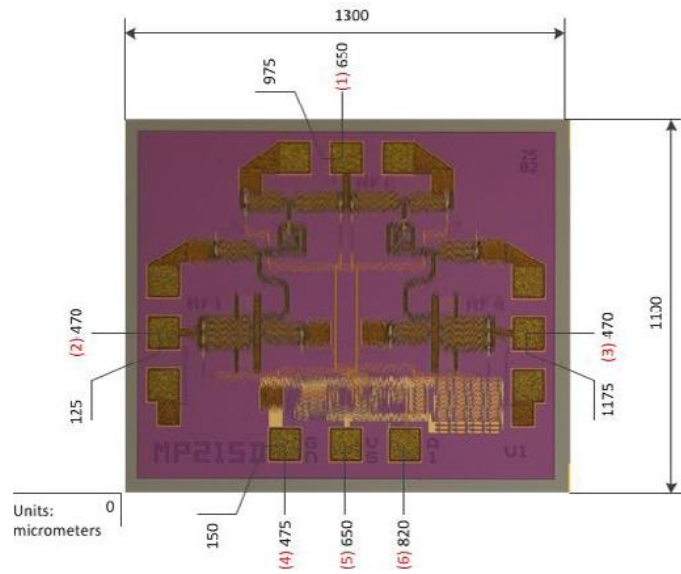

- Chip size 1 300 × 1 000 μm (before wafer dicing), thickness 100 μm.
- Position coordinates are shown for the bond pad center.
- Bond pad and backside are metallized with gold.
- RF pads are 100 × 100 μm.

Pad number	Port	Description
1	RFC	Common RF port
2	RF1	Output RF port №1
3	RF2	Output RF port №2
4	GND	Decoupling ground
5	VS	Supply of digital control driver
6	A1	Control of switch cells state

Application notes

Mounting

The chip is back-metallized with gold and can be die mounted with AuSn eutectic alloy or with electrically conductive adhesive. The mounting surface should be clean and flat. The 50 Ohm Microstrip transmission, mounted on 0.127 mm thick alumina and thin film substrates, is recommended for bringing RF to and from the chip (Figure 1). One way to accomplish this is to attach the 0.102 mm thick die to a 0.150 mm thick molybdenum heat spreader (molytab) which is then attached to the ground plane (Figure 2). Microstrip substrates should be located as close to the die as possible in order to minimize bond wire length. Typical die-to-substrate spacing is 0.1mm.

Wire Bonding

It is recommended for RF pads (1...3) to use one wire 25 µm in diameter, 400 µm in length. The recommendation for DC and control pads (4...10) is one wire 25 µm in diameter and 700...1 000 µm in length

Voltage supply

The DC bias pad №5 needs to have a bridging capacitor of 100 pF as close to the device as possible.

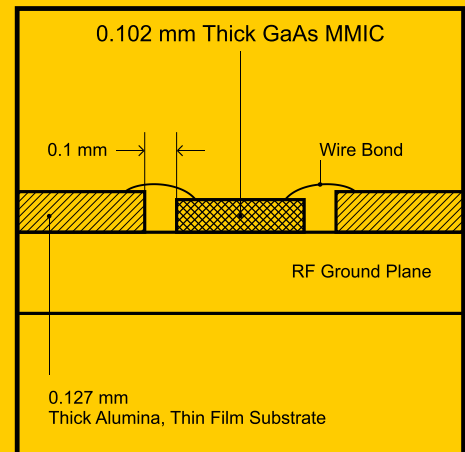

Figure 1.

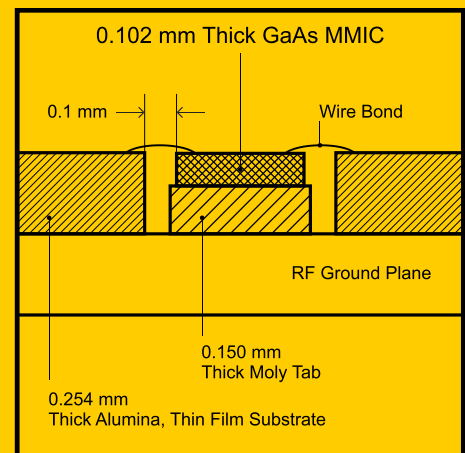

Figure 2.

Recommended ESD Management

This device is susceptible to electrostatic and mechanical damage. Dies are supplied in antistatic containers, which should be opened in cleanroom conditions at an appropriately grounded antistatic workstation. Devices need careful handling using correctly designed collets, vacuum pickups or, with care, sharp tweezers.

