

MD607

Double Balanced Mixer 10...20 GHz



- frequency range 10...20 GHz
- frequency range IF от DC до 6 GHz
- conversion loss < 10 dB
- passive double balanced topology
- input power (P1dB) > 10 dBm

Application

- communications
- radars
- test and measurement equipment

The MD607 is a passive double balanced mixer that can be used as an up- or downconverter between 9.0 and 20.0 GHz. The miniature monolithic mixer is based on GaAs QSBD process, and requires no external components or matching circuitry. The chip is ideally suited for applications where small size, no DC bias, and consistent IC performance are required. This mixer can operate over a wide LO drive input of +10 to +15 dBm. The MMICs use gold bond pads and backside metallization, and are fully protected with Silicon Nitride passivation to obtain the highest level of reliability.

Electrical specification (T = 25 °C, F_{IF} = 0.1 GHz, P_{LO} = +13 dBm)*

Symbol	Parameter	Min.	Typ.	Max.	Unit
ΔF_{RF}	Frequency range, RF	10	—	20	GHz
ΔF_{LO}	Frequency range, LO	10	—	26	GHz
ΔF_{IF}	Frequency range, IF	DC	—	6	GHz
C _L	Conversion loss	—	10	—	dB
NF	Noise figure	—	10	—	dB
I _{LO-RF}	LO to RF Isolation	37	—	—	dB
I _{LO-IF}	LO to IF Isolation	34	—	—	dB
I _{RF-IF}	RF to IF Isolation	10	—	—	dB
P1dB	1 dB Gain compression (input)	—	10	—	dBm

REMARK *Unless otherwise noted, all measurements performed as downconverter, F_{IF} = 0.1 GHz, P_{LO} = +13 dBm

Absolute maximum ratings

Parametr	Value	Unit
RF input	+20	dBm
LO drive	+20	dBm
Operating temperature	-60...+85	°C
Storage temperature	-60...+125	°C

Typical characteristics (T = 25 °C)

Conversion gain vs IF

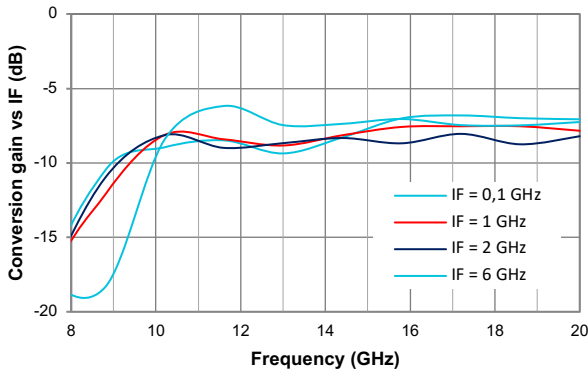

Conversion gain vs P_{LO}

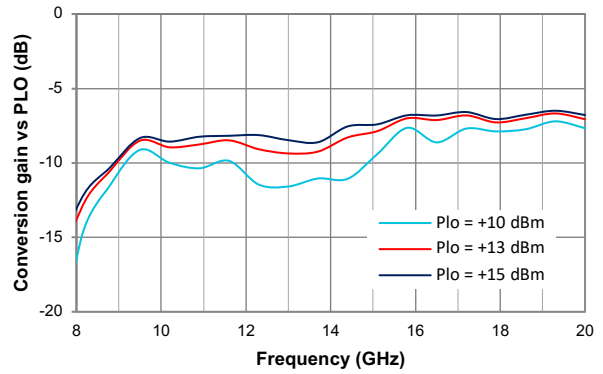

Up Conversion gain vs P_{LO}

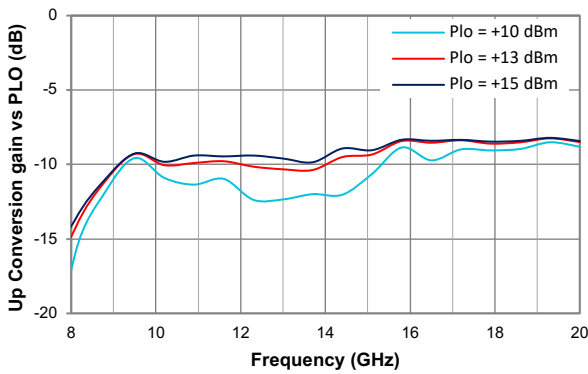

Isolations

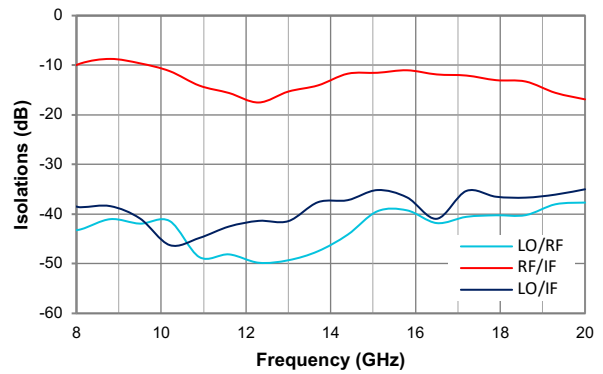

Reflection Loss

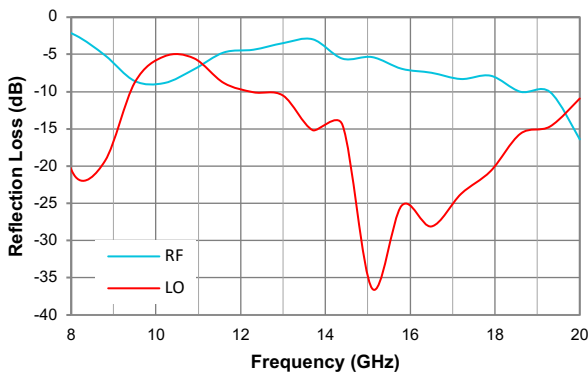

Mechanical data

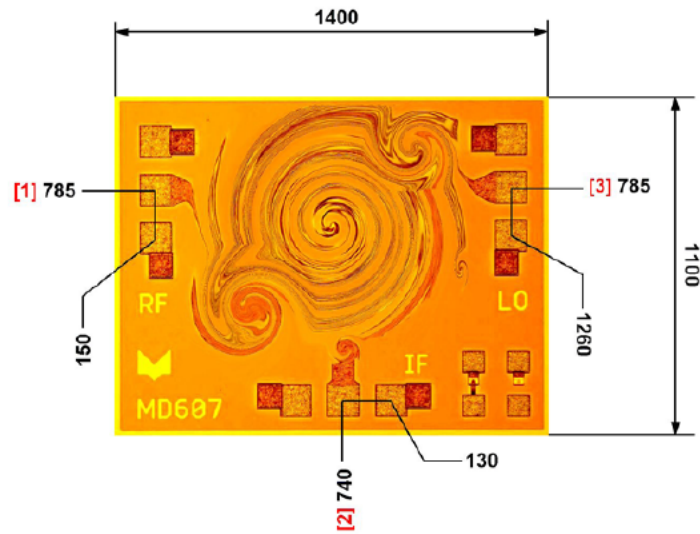

- Chip size 1400 × 1100 μm (before wafer dicing), thickness 100 μm;
- Bond pad dimensions are shown to a centre of a bond pad;
- Bond pad and backside metallization: gold;
- RF pads are 100 × 100 μm.

Pad number	Port	Discription
1	RF	RF input / output
2	IF	IF input / output
3	LO	LO input

Application notes

Mounting

The chip is back-metallized and can be die mounted with AuSn eutectic preforms or with electrically conductive epoxy. The mounting surface should be clean and flat. The 50 Ohm Microstrip transmission lines on 0.127mm thick alumina thin film substrates are recommended for bringing RF to and from the chip (Figure 1). One way to accomplish this is to attach the 0.102 mm thick die to a 0.150 mm thick molybdenum heat spreader (molytab) which is then attached to the ground plane (Figure 2). Microstrip substrates should be located as close to the die as possible in order to minimize bond wire length. Typical die-to-substrate spacing is 0.1mm.

Wire Bonding

Microstrip substrates should be brought as close to the die as possible in order to minimize ribbon bond length. Recommendation for RF pads is one wire: diameter 25 µm, length 450 µm.

DC coupling

All ports are DC coupled. For applications not requiring operation to DC, those ports should be DC blocked externally using a series capacitor whose value has been chosen to pass the necessary frequency range.

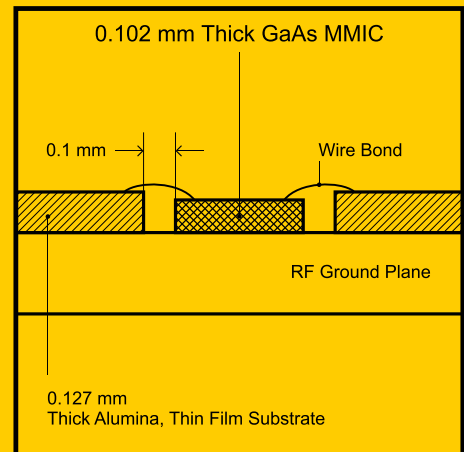

Figure 1.

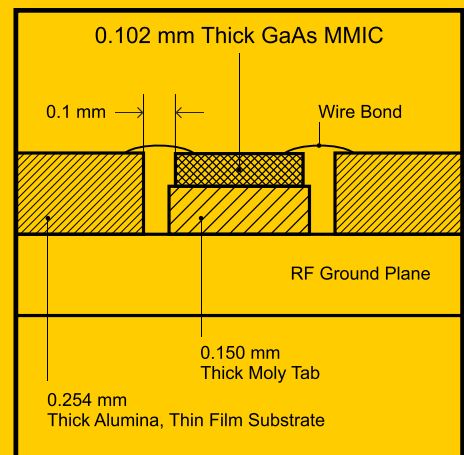

Figure 2.

Recommended ESD Management

This device is susceptible to electrostatic and mechanical damage. Dies are supplied in antistatic containers, which should be opened in cleanroom conditions at an appropriately grounded antistatic workstation. Devices need careful handling using correctly designed collets, vacuum pickups or, with care, sharp tweezers.

